

ECOSOLAR 150 CRN: INSTALLAZIONE SU TETTO PIANO

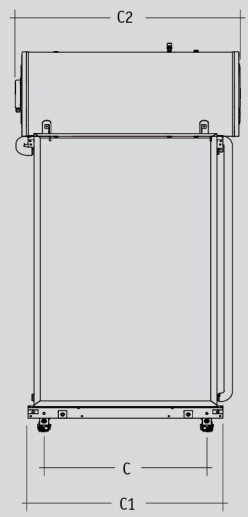

ECOSOLAR 150 CRN: INSTALLAZIONE SU TETTO INCLINATO (ST)

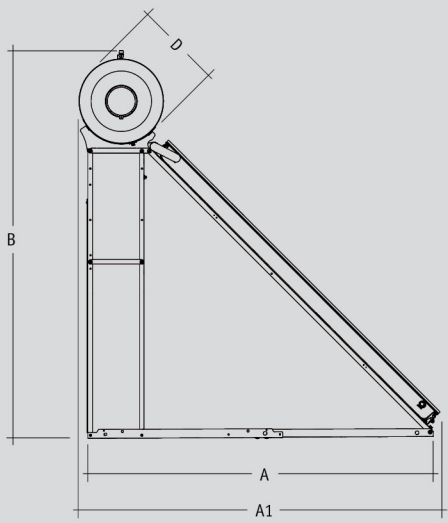
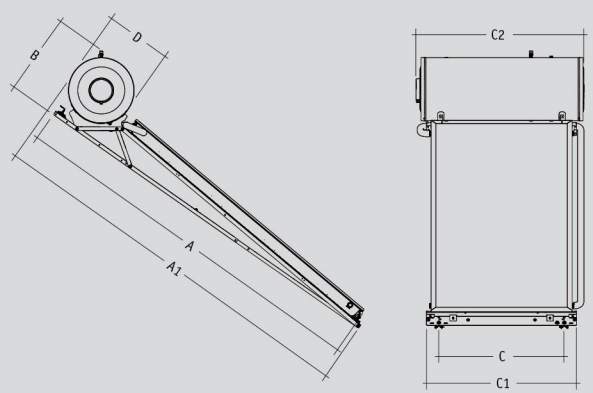

ECOSOLAR 150 CRN: INSTALLAZIONE SU TETTO INCLINATO (ST/FF)

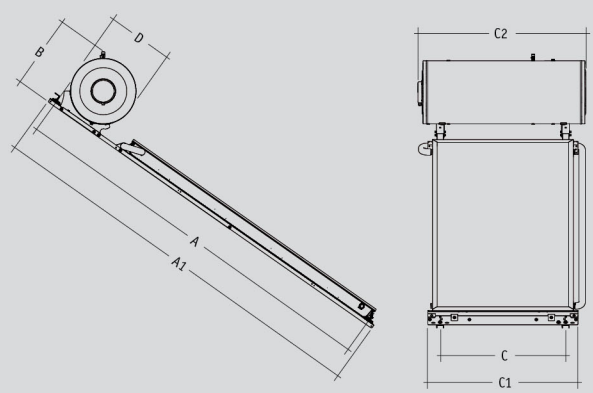

| Modello | Codice** | Dimensioni (mm) | | | Peso | Peso |
|---------------------------------------|-----------|------------------|--------------------------|-----------------------------|---------------|---------------|
| | | 150 CRN mm | 150 CRN (ST) mm | 150 CRN (ST/FF) mm | a vuoto Kg | a pieno Kg |
| EcoSolar 150 CRN 2.2 mq | 006225000 | | | | 152 | 300 |
| A | | 2058 | 2874 | 2058 | | |
| A1 | | 2443 | 2943 | 3053 | | |
| B | | 2310 | 620 | 560 | | |
| C | | 970 | 970 | 970 | | |
| C1 | | 1161 | 1161 | 1161 | | |
| C1 (con copertura estetica opzionale) | | 1337 | 1337 | 1337 | | |
| C2 | | 1300 | 1300 | 1300 | | |
| D | | 500 | 500 | 500 | | |